

Coping With Bats in Montana Homes

by James Knight, Extension Wildlife Specialist

For reasons of health, odor and cleanliness, most people do not wish to live in close proximity with bats. Their nocturnal movements and quick flight patterns often give us cause for alarm.

But despite their “reputation,” bats provide millions of dollars worth of benefits that should be recognized. Bats are crucial to pollination of many plants, they reduce disease vectors, and they fill a key ecological niche.

This MontGuide describes some of the characteristics of bats and offers several solutions for coping with bats who have taken up residence in human households.

Characteristics of bats

Bats are small mammals, averaging three to five inches in length.

A few species are solitary, but most bats congregate in groups or

colonies. Most leave their roosting places at dusk to fly about in pursuit of the night-flying insects that provide the bulk of their food.

All bats in Montana are insectivorous, feeding on a variety of flying insects. Many of these insects are harmful to humans. A bat can consume insects equal to one-third of its body weight in $\frac{1}{2}$ hour of foraging. The bat may fill its stomach in about one hour with prey including beetles, moths, flying ants, true bugs, mayflies, caddis flies and other insects. The nightly consumption of insects by a colony of bats can be extremely large.

Two bats common in Montana are the big brown bat and the hoary bat (Figure 1). Bats in Montana migrate with the change in seasons, following a steady source of food supply. Some bats come to Montana only during the colder months.



Figure 1. Hoary bat

By day, bats roost in dark, sheltered places. They hang head-down, firmly secured by hooking their toes into cracks or around small projections. From this position they drop from the roost by releasing their grasp. Momentum from the fall helps them become airborne. Most bats cannot take off from a flat surface.

Originally, bats roosted in natural shelters, such as caves and hollow trees. Many still do, but others have found attics, spaces between building walls and unused areas in upper stories much to their liking. The noises created by



crawling and squeaking bats are usually disturbing to the householder.

The major objection to their presence in buildings is the bat excrement. This excrement persists for a long time after the roost is broken up, and some experts speculate it may serve to attract new colonies if thorough sanitary measures are not taken.

Bat excrement

Bat excrement (guano) produces an unpleasant odor as it decomposes in attics, wall spaces and other voids. The pungent, musty, acrid odor can often be detected from outside a building containing a large or long-term colony. Similar odor problems occur when animals die in inaccessible locations. The odor also attracts arthropods, which may later invade other areas of a building.

Bat guano may provide a growth medium for microorganisms, some of which are pathogenic (histoplasmosis, for example). Excessive guano can lead to stained ceilings, soffits and siding, producing unsightly and unsanitary conditions.

Bats also urinate and defecate in flight, causing multiple spottings and stains on sides of buildings, windows, patio furniture, automobiles and other objects at and near entry/exit holes or beneath roosts. Bat excrement may contaminate stored food, commercial products and work surfaces. Although the fresh urine of a single bat is relatively odorless, that of any moderate-sized colony is obvious, and the odor increases during damp weather.

The close proximity of bat roosts to human living quarters can result in excreta, animal dander, fragments of arthropods and various microorganisms entering air

ducts as well as falling onto the unfortunate residents below. Such contaminants can result in airborne particles of public health significance.

Rabies

Bats, like any other mammal, can transmit the rabies virus to humans. Domestic dogs, domestic cats, skunks, foxes and bats have a higher occurrence of rabies than other mammals. Any bat acting in an abnormal manner should be approached with caution, particularly if found fluttering on the ground. Bat bites should be treated by a physician, and the bat should be captured without injury to the head so the brain can be examined by proper authorities.

Control techniques

The only way to permanently rid a building of bats is to eliminate all possible entrances. Repellents are not lasting control methods, and there are no toxicants registered for bats in Montana. Bat-proofing a building is the only efficient and permanent way to eliminate bats.

Bat-proofing buildings

Bats may enter buildings through large or small openings such as unprotected louvers or vents, broken windows or other open spaces. They may enter through old worn sidings or around eaves or cornices. The smaller species of bats can crawl through slits as narrow as 3/8 of an inch. It is necessary, therefore, to eliminate all possible entrances.

The larger openings should be covered with sheet metal or with 1/4-inch mesh hardware cloth if ventilation is necessary. It is essential that no openings larger than 1/4-inch are left. Many openings

are best plugged and sealed with caulking compound. Foam injected in cracks, crevices, roof edges, door jambs, overhangs and similar openings can eliminate smaller entrances.

Control steps

To begin bat control, first identify the primary entrances used by the bats. Do not close these until after the bats have had two opportunities to leave the roost.

In the evening, about 30 minutes before dark, observe the area you suspect the bats may be using. You will probably be able to identify one or two spots they are using to enter and exit. The next day, plug all holes except the few you have identified as entrances or exits. This will allow the bats to leave the roost and these remaining holes can be plugged later. Be sure the holes you leave are being actively used by bats. A brown stain is usually apparent at the actively used entrances.

During the warmer months, bats normally have two feeding flights, one in early evening and one in the early morning. Normally, all occupants leave the roost within 15 to 20 minutes after the first one starts out. If they have been disturbed, however, the normal routine may be upset considerably.

The next step is to close the remaining holes in the evening about one hour after dark. They can be reopened for a few days just before dark to allow any remaining bats to leave. Remember, however, to close all entrances every night about one hour after dark. If any entrances have been overlooked, the bats will soon find them. It may be necessary to watch the building closely at dusk for several evenings.

One concern with this technique

relates to the presence of dependent young. If the bats are locked out while they have dependent young, it will cause mortality and a resulting odor. Males are often in small groups, (one to 20 for most species) and widely scattered. If possible, look into the roost for young bats.

Excluding a colony

Most bat species leave in winter, permitting exclusion in their absence. If you do not wish to wait for winter, there is a relatively simple exclusion technique that can be used after young are flying but prior to the winter months.

Inexpensive light-weight polypropylene netting with a mesh-size of 1/4-inch or smaller can be obtained in quantity to cover areas of nearly any size. Hang the netting during daylight hours above areas where bats emerge, using duct tape or staples (Figure 2). A strip of net-

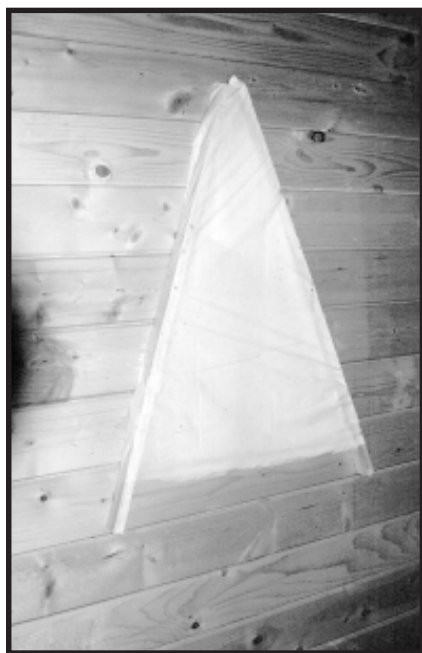

Fig. 2 Sample uses of plastic sheeting to allow bats to exit without opportunity for reentry

ting at least two feet wide, hung one to two inches in front of bat exit holes, and extending at least two feet below and to the side of exit points will allow the bats to emerge, but later they will be unable to find their way back. The netting acts as a simple one-way excluder until repairs can make the exclusion permanent. A sheet of clear, heavy-weight plastic (available at any hardware store) will have the same effect. The netting (or plastic) should be left in place for two to three days to assure that all bats have left the roost.

Repellents

Occasionally, temporary control can be accomplished by the use of repellents. Bats dislike the odor of naphthalene, a chemical commonly used as a moth and insect repellent. When the roost is located in attics or other closed spaces that can be reached easily, either of these materials may be used to temporarily drive them out. Three to five pounds of naphthalene flakes will usually be sufficient to treat the average attic. Sprinkle the material liberally over the entire area. Bats will usually leave the roost within a short time after it is introduced. The chemical dissipates rapidly on contact with air, however, and application has to be repeated often if no other control is practiced.

Bright lights used to illuminate the roost may also act as a repellent.

These techniques can be employed to remove bats while bat-proofing is being completed. The repellent techniques should not be considered a permanent solution to bat problems. Remember, bats are quite persistent, and it is often difficult to dislodge them from old established roosts.

Removal of occasional bat intruders

A bat that has blundered into the living quarters of a house will usually find its way out by detecting air movement. When no bite or contact with people or pets has occurred, the simplest solution for “removing” the bat is to try to confine it to one room, then open windows and doors leading outdoors and allow it to escape.

If the bat is present at night, the lights should be dimmed to allow the animal to find open doors and windows; some light is necessary if an observer is to ensure that the bat finds its way out. If bright lights are kept on, the bat may become confused and may seek refuge behind shelving, curtains, hanging pictures, or under furniture.

Healthy bats normally will not attack people, even when chased. Chasing a flying bat with a folded newspaper, tennis racket or stick will cause the bat to take evasive action, and a bat’s flight reversal to avoid a wall is often misinterpreted as an attack. These flailings, often futile, will cause a bat to seek safety wherever possible, making escape more difficult for the bat and more frustrating for the human.

If the bat has difficulty escaping, it can be captured in a hand net (for example, an insect net). Otherwise, wait for it to come to rest, quickly cover it with a coffee can or similar container, and slide a piece of cardboard or magazine under the can to trap the bat inside. Take the captured bat outdoors and release it away from populated areas, preferably after dark. Note that reasonably thick work gloves should be worn at all times when trying to capture a bat. Also, if a bite or physical contact occurs, capture the bat without damaging its head and immediately contact a physician.

Bat houses

For more than 60 years, artificial bat roosts have been used in Europe. Only recently have they gained some popularity in the United States. Though the results are variable, it appears that artificial houses, if properly constructed and located, can attract bats that are displaced or excluded from a structure (Figure 3). It sometimes helps to seed a new bat house with guano from the excluded site.

Alternate roosts should be located away from human high-use areas. Thus, people can enjoy the benefits of bats without sharing their dwellings with them and with little risk of direct contact with them.

Summary

Bats are often misunderstood. They perform a valuable natural function but are understandably unwelcome when they take up residence in certain places. Exclusion or "bat-proofing" is the only sure solution to a bat problem.

Lumber needed:

- 1" x 8" x 15³/₄"—5 pieces (2 for front, 3 for back)
- 1" x 4" x 15³/₄"—1 piece for front
- 1" x 4" x 16¹/₂"—1 piece for top
- 1" x 1" x 12³/₄"—1 piece for entry restriction
- 2" x 2" x 21³/₄"—2 pieces for sides
- 2" x 2" x 12³/₄"—1 piece for ceiling
- Piece of nylon screening, 19³/₄" long x 14¹/₄" wide.

Fold sides and top over ³/₄"

Note: the dimensions shown on the diagram are trimmed sizes, e.g., a 1" x 4" piece of lumber is actually ³/₄" x 3¹/₂"

FIGURE 3. Plans for a bat house

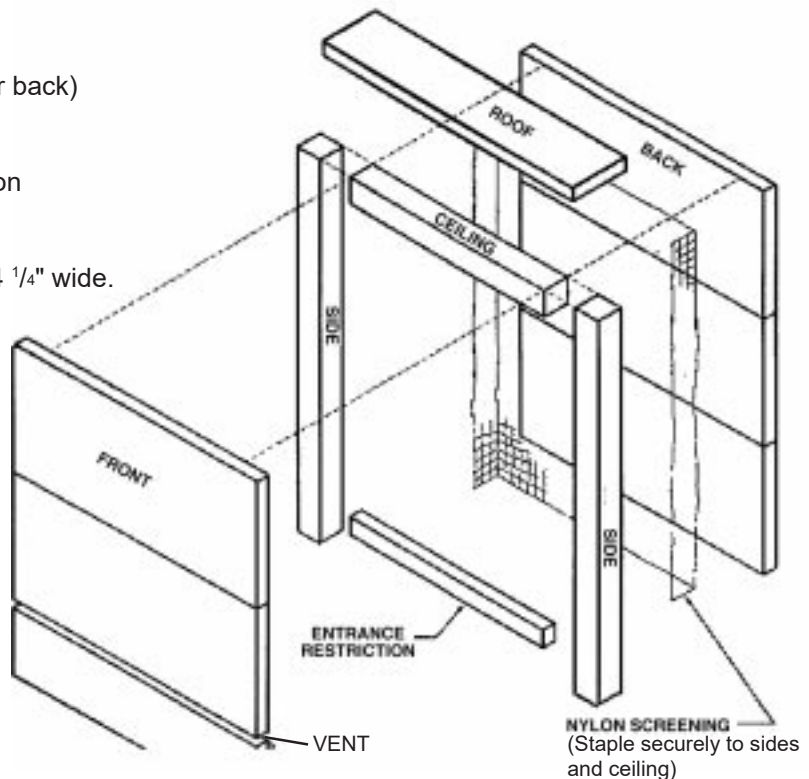
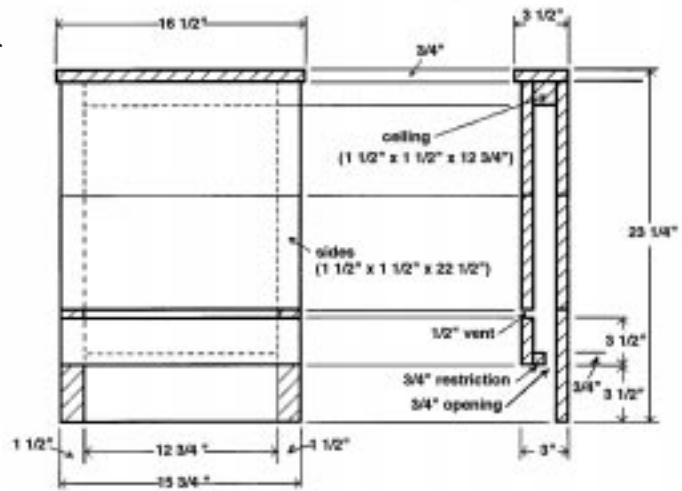

Copyright 2000 MSU Extension Service

We encourage the use of this document for non-profit educational purposes. This document may be reprinted if no endorsement of a commercial product, service or company is stated or implied, and if appropriate credit is given to the author and the MSU Extension Service. To use these documents in electronic formats, permission must be sought from the Ag/Extension Communications Coordinator, Communications Services, 416 Culbertson Hall, Montana State University-Bozeman, Bozeman, MT 59717; (406) 994-2721; E-mail - apbtk@montana.edu.

The programs of the MSU Extension Service are available to all people regardless of race, creed, color, sex, disability or national origin. Issued in furtherance of cooperative extension work in agriculture and home economics, acts of May 8 and June 30, 1914, in cooperation with the U.S. Department of Agriculture, David A. Bryant, Vice Provost and Director, Extension Service, Montana State University, Bozeman, MT 59717.

File under: Wildlife

B-2 (Non-game animals)

Issued Aug. 2000 (3292000800 ST)

