

Scott R. Craven

Extension Wildlife Specialist
Department of Wildlife Ecology
University of Wisconsin-Madison
Madison, Wisconsin 53706

Scott E. Hygnstrom

Extension Wildlife Damage Specialist
Department of Forestry, Fisheries
and Wildlife
University of Nebraska
Lincoln, NE 68583

DEER



Fig. 1. White-tailed deer, *Odocoileus virginianus*

Damage Prevention and Control Methods

Exclusion

Fences provide the most consistent control:

8-foot (1.4-m) woven wire fence, Tensar®, or wooden snow fence around small plots or haystacks.

Several configurations of electric fences are available:

vertical five, seven, or nine-wire, slanted seven-wire, single strand, and others.

Individual tree protectors include: woven wire or plastic cylinders.

Cultural Methods and Habitat Modification

Plant trees and shrubs that are resistant or less susceptible to deer damage.

Harvest crops as early as possible to reduce vulnerability.

Lure crops may divert deer away from areas that are susceptible to damage.

Habitat modification generally is not recommended.

Frightening

Gas exploders, pyrotechnics, gunfire, or tethered dogs provide temporary relief.

Repellents

A wide variety of commercial formulations is available: area repellents--applied near plants to be protected, repel by smell;

contact repellents--applied directly to plants to be protected, repel by taste;

a few, such as Deer-Away®, possess characteristics of both groups.

Toxicants

None are registered.

Live Capture

Deer can be live-trapped or chemically immobilized for removal by professional biologists--useful only in special cases, such as city parks.

Shooting

Sport hunting can reduce deer populations and should be encouraged.

Some states may issue permits to shoot deer outside normal sport hunting seasons.

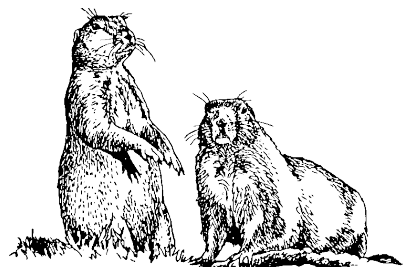

PREVENTION AND CONTROL OF WILDLIFE DAMAGE — 1994

Cooperative Extension Division
Institute of Agriculture and Natural Resources
University of Nebraska - Lincoln

United States Department of Agriculture
Animal and Plant Health Inspection Service
Animal Damage Control

Great Plains Agricultural Council
Wildlife Committee

Introduction

Deer are probably the most widely distributed and best-recognized large mammals in North America. The white-tailed deer (*Odocoileus virginianus*) (Fig. 1) is found throughout much of North America. The mule deer (*O. hemionus*) is primarily a western species restricted to buttes, draws, and stream bottoms with sufficient forage. The black-tailed deer (*O.h. columbianus*) is a subspecies of the mule deer. Both white-tailed and mule deer are very important game animals. In 1974 about 2 million white-tailed deer were harvested by over 8 million hunters. The trend in both harvest and hunter numbers has been generally upward since then. The positive economic value of deer through license fees, meat, and hunter expenditures for equipment, food, and transportation can be measured in hundreds of millions of dollars. Hesselton and Hesselton (1982) estimated the value of each deer harvested in the United States to be \$1,250. With the additional aesthetic value of deer to landowners and vacationers, importance of deer as a wildlife resource cannot be disputed.

Despite their economic and aesthetic values, deer also have a variety of negative economic impacts—they damage crops and personal property, and harbor diseases common to humans and livestock. Unlike moles, rats, and other species implicated in damage, deer cannot be casually eliminated when in conflict with humans. But neither can landowners be expected to bear the entire burden of support for this valuable public resource.

These factors often make deer damage control a difficult social and political problem as well as a biological and logistical one. Control methods are built around effective deer herd management. Thus the various state wildlife agencies are often indirectly or directly involved through subsidy of control techniques, direct damage compensation payments, or technical advice.

Scare devices, repellents, and shooting all have a place in deer damage control. Effective control for fields, orchards, and other large areas, however, usually depends on excluding the deer with one of several types of fences, discussed later in this chapter. Toxicants, fumigants, and in most cases, trapping, are not used in deer control.

The volume of literature on deer ecology and management exceeds that for any other wildlife species. The best single reference is Halls (1984). The following review is meant as a brief summary using the white-tailed deer as an example. The mule deer is very similar in all respects.

Identification

Deer are even-toed ungulates of the family *Cervidae*. Adult animals may weigh 50 to 400 pounds (23 to 180 kg) depending on species and location. Their general form is well-known. At birth, fawns are rust-colored with white spots. Their spotted coats are shed in 3 to 4 months and are replaced by a grayish-brown fall and winter coat. The summer coat of adult animals is reddish-brown. Underparts of the tail, belly, chin, and throat are white during all seasons. Antlers grow on males (bucks) from April to August. Antler development is nourished by a layer of soft, vascularized “velvet” on the antlers. The dried velvet layer is rubbed off and the antlers polished during the fall rut (breeding season). Antler size depends on nutrition, age, and genetics. Mule deer antlers are forked while the tines of a white-tailed deer’s antlers arise from a central beam. Both mule deer and white-tails have deciduous antlers that are shed in mid-winter. The rump and tail area and facial features also differ slightly between the species (Fig. 2). Both mule and white-tailed deer lack upper incisors.



White-tailed deer

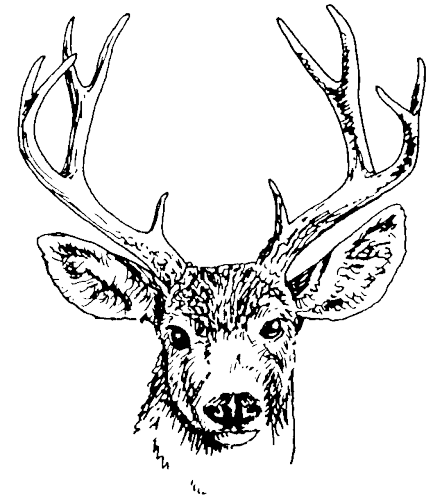

Black-tailed deer



Mule deer

Fig. 2. Comparison of antlers and facial characteristics, metatarsal glands, tails, and rump patches in three kinds of deer.

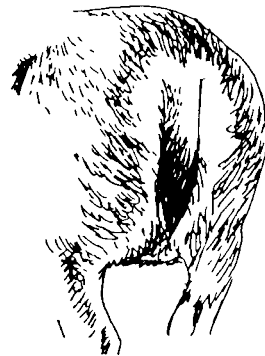
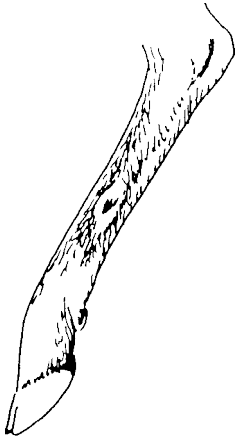

Range

The white-tailed deer is found in every state in the United States except perhaps Alaska and Utah. It occurs throughout the southern provinces of Canada, across the United States, and on into Central and South America (Fig. 3). Mule deer are common throughout western Canada, western United States, and into Mexico (Fig. 4). There are several subspecies of both deer.



Fig. 3. Range of the white-tailed deer in North America.

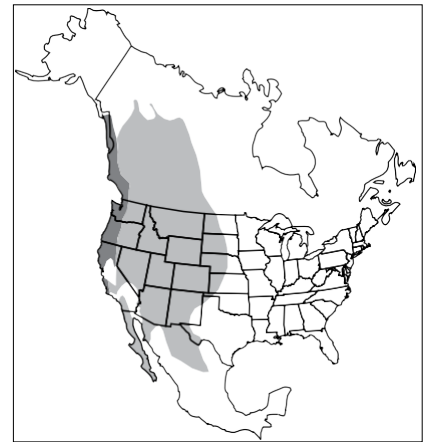

Fig. 4. Range of the mule deer (light) and black-tailed deer (dark) in North America.

Habitat

Deer are creatures of the forest edge rather than the dense, old-growth forest. They thrive in agricultural areas interspersed with woodlots and riparian habitat. They favor early successional stages which keep brush and sapling browse within reach. Dense cover is used for winter shelter and protection.

Food Habits

Browse (leaves, stems, and buds of woody plants) is generally available all year and is a staple food for deer. An extensive review of food habits can be found in Hesselton and Hesselton (1982) and in Mackie et al. (1982). Plant species vary considerably in quality and regional availability, so a list is not presented here. Forbs are eaten in spring and summer when available. Fruits and nuts (especially acorns) are seasonally very important. Grasses are relatively unimportant. Agricultural crops—corn, soybeans, small grains, alfalfa, vegetables, and fruit trees—are readily eaten when available. Local food habits studies are available in most states—consult your local wildlife agency.

Nutrient requirements and the amount of food consumed vary with age of the animal, season, and the reproductive cycle. Daily dry matter consumption averages 2% to 4% of live body weight. For adult bucks, daily consumption is greatest in spring and averages 4.4 to 6.4 pounds (2.0 to 2.9 kg) of air-dry food per day. Consumption is about half that during winter. For does, greatest daily food consumption occurs in early fall, just prior to the breeding season.

General Biology, Reproduction, and Behavior

Breeding occurs from October to January depending on latitude. Peak activity is in November. Does are in heat for 24 hours every 28 days for 2 to 3 consecutive cycles. One buck may inseminate several does. No pairing takes place. Most does breed during their second fall, although on good range up to 30% of the doe fawns (6 months old) will be bred. Gestation is about 202 days. The peak of fawn drop is in May or June. Most reproducing fawns give birth to a single fawn, but adult does typically bear twin fawns. Reproductive potential is very sensitive to nutrition. Fawns weigh 7 to 8 pounds (3.2 to 3.6 kg) at birth and increase in weight for 5 1/2 to 6 1/2 years. Adult size varies with latitude. In northern states, a mature buck may weigh 200 to 300 pounds (90 to 135 kg). A key deer buck (white-tailed deer subspecies) in Florida may weigh only 50 pounds (22.5 kg). Does average 25% to 40% less than bucks for all subspecies.

Deer are most active in early morning and evening. They have a home range of several hundred acres (ha), but this varies with season, sex, and habitat quality. In northern areas, deer gather ("yard") in dense cover for the winter. They may move long distances from summer range to a winter yard. Life expectancy is dependent on hunting pressure and regulations. Records show whitetails living 20 years, although 10 to 12 years is noteworthy in the wild.

Damage and Damage Identification

Deer damage a wide variety of row crops, forage crops, vegetables, fruit trees, nursery stock, and ornamentals, as well as stacked hay. In addition to the immediate loss of the crop being damaged, there is often residual damage in the form of future yield reduction of fruit trees or forage crops such as alfalfa. Ornamental trees or nursery stock may be permanently disfigured by deer browsing. Under high densities deer may severely impact native plant communities and impair regeneration of some forest tree species. Besides vegetative damage, deer/vehicle collisions pose a serious risk to motorists, and deer have been implicated in the distribution and transmission of Lyme disease.

Damage identification is not difficult. Because both mule deer and white-tailed deer lack upper incisors, deer often leave a jagged or torn surface on twigs or stems that they browse. Rabbits and rodents, however, leave a clean-cut surface. In addition, deer tracks are very distinctive (Fig. 5). The height of damage from the ground (up to 6 feet [1.8 m]) often rules out any mammal other than deer. Deer often are observed "in the act" of causing damage.

Legal Status

Deer are protected year-round in all states and provinces, with the exception of legal harvest during appropriate big-game hunting seasons. In cases of severe or persistent damage, some states may issue farmers special permits to shoot deer at times other than the legal hunting seasons. Regulations vary on the necessary permits and on



Fig. 5. Deer tracks

disposal of dead animals. The popularity of deer as game animals and the need to curb poaching have led to the development of severe penalties for illegal possession. No lethal deer control can be initiated before consulting your local state wildlife agency. By law, some states provide technical assistance or direct compensation for deer damage. This is discussed under the section on the economics of damage and control.

Damage Prevention and Control Methods

Exclusion

Where deer are abundant or crops are particularly valuable, fencing may be the only way to effectively minimize deer damage. Several fencing designs are available to meet specific needs. Temporary electric fences are simple inexpensive fences useful in protecting garden and field crops during snow-free periods. Deer are attracted to these fences by their appearance or smell, and are lured into contacting the fence with their noses. The resulting shock is a very strong stimulus and deer learn to avoid the fenced area. Permanent high-tensile electric fences provide year-round protection from deer and are best suited to high-value specialty or orchard crops. The electric shocking power and unique fence designs present both psychological and physical barriers to deer. Permanent woven-wire fences provide the ultimate deer barrier. They require little maintenance but are very expensive to build. Fencing in general is

expensive. You should consider several points before constructing a fence, such as:

History of the area — assemble information on past claims, field histories, deer numbers, and movements to help you decide on an abatement method.

Deer pressure — this reflects both the number of deer and their level of dependence on agricultural crops. If deer pressure in your area is high, you probably need fences.

Crop value — crops with high market values and perennial crops where damage affects future yields and growth often need the protection fencing can provide.

Field size — in general, fencing is practical for areas of 40 acres (16 ha) or less. The cost per acre (ha) for fencing usually decreases, however, as the size of the area protected increases.

Cost-benefit analysis — to determine the cost effectiveness of fencing and the type of fence to install, weigh the value of the crop to be protected against the acreage involved, costs of fence construction and maintenance, and the life expectancy of the fence.

Rapidly changing fence technology — if you intend to build a fence yourself, supplement the following directions by consulting an expert, such as a fencing contractor. Detailed fencing manuals are also available from most fencing manufacturers and sales representatives.

Temporary Electric Fencing

Temporary electric fences provide inexpensive protection for many crops during periods without snow. They are easy to construct, do not require rigid corners, and materials are readily available. Install fences at the first sign of damage to prevent deer from establishing feeding patterns in your crops. Weekly inspection and maintenance are required. Different types of temporary electric fences are described below.

Peanut Butter Fence. The peanut butter fence is effective for small gardens, nurseries, and orchards (up to 3 to 4 acres [1.2 to 1.6 ha]) subject to moderate deer pressure. Deer are attracted by the peanut butter and encouraged to make nose-to-fence contact. After being shocked, deer learn to avoid fenced areas. Cost, excluding labor, is about \$0.11 per linear foot (\$0.30/m). This fence is not widely used.

To build a peanut butter fence (Fig. 6), follow the steps below.

- (1) Install wooden corner posts.
- (2) String one strand of 17-gauge (0.15-cm), smooth wire around the corners and apply light tension.
- (3) Set 4-foot (1.2-m) 3/8-inch (1-cm) round fiberglass rods along the wire at 45-foot (14-m) intervals.
- (4) Attach the wire to insulators on the rods 2 1/2 (0.75 m) feet above ground level and apply 50 pounds (22.5 kg) of tension.

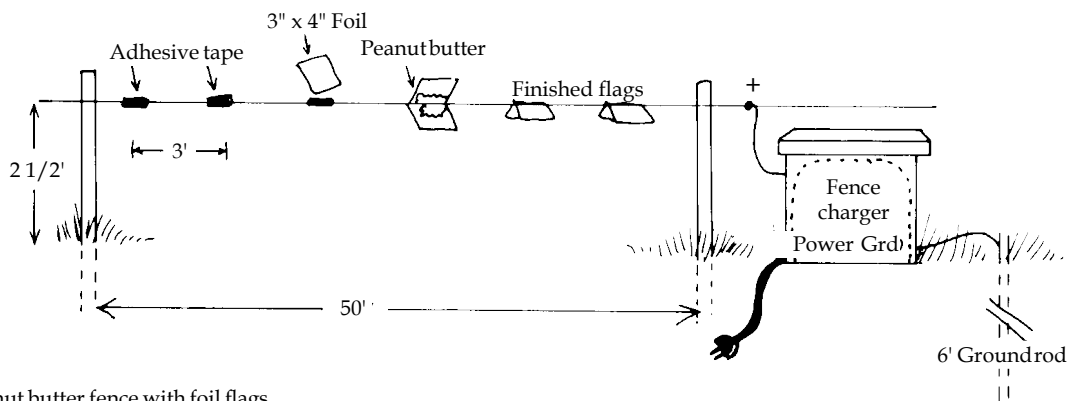

Fig. 6. The peanut butter fence with foil flags.

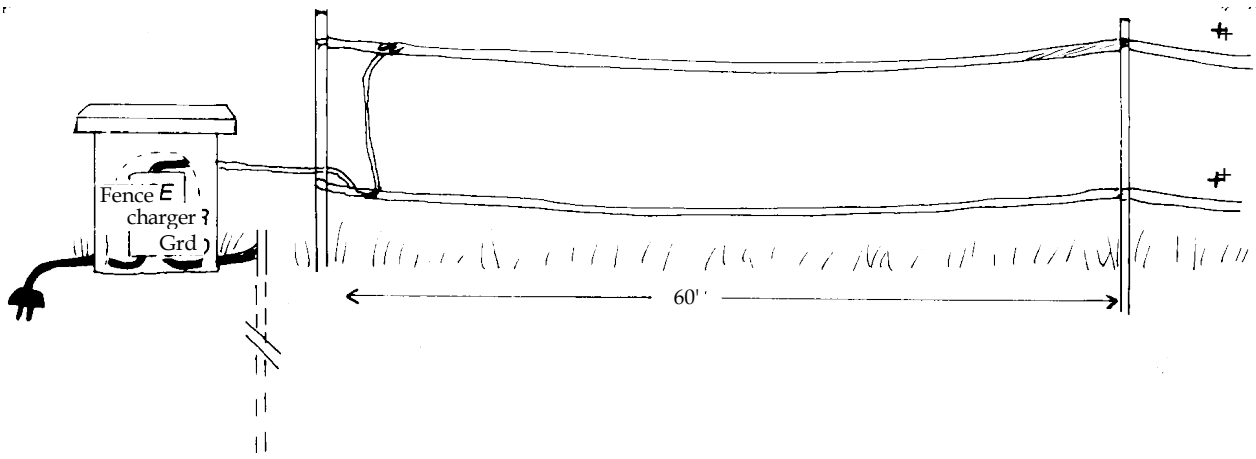

Fig. 7. The polytape fence.

- (5) Attach 3 x 4-inch (7 x 10-cm) foil strips to the wire at 3-foot (1-m) intervals, using 1 x 2-inch (3 x 5-cm) strips of cloth adhesive tape.
- (6) Apply a 1:1 mixture of peanut butter and vegetable oil to the adhesive tape strips and fold the foil over the tape.
- (7) Connect the wire to the positive (+) post of a well-grounded fence charger.
- (8) For fields larger than 1 acre (0.4 ha), it is more practical to apply the peanut butter mixture directly to the wire. You can make a simple applicator by mounting a free-spinning, 4-inch (10-cm) pulley on a shaft inside a plastic ice cream pail. Fill the pail with a peanut butter-vegetable oil mixture that has the consistency of very thick paint. Coat the entire wire with peanut butter by drawing the pulley along the wire. Apply peanut butter once a month. Attach foil flags to the fence near runways or areas of high deer pressure to make the fence more attractive.

Check the fence weekly for damage by deer and grounding by vegetation.

Polytape Fence. Various forms of polytape or polywire, such as Visible Grazing Systems® (VGS), Baygard®, and Turbo-tape® are very strong and portable. You can use these fences to protect up to 40 acres (16 ha) of

vegetable and field crops under moderate deer pressure. Deer receive shocks through nose-to-fence contact and they learn to avoid fenced areas. Cost, excluding labor, is about \$.11 per linear foot (\$0.30/m).

To build a polytape fence (Fig. 7), follow the steps below.

- (1) Drive 5/8-inch (1.6-cm) round fiberglass posts 2 feet (0.6 m) into the ground at the corners.
- (2) String two strands of polytape (white or yellow are most visible) around the corners and apply light tension (one strand 2 1/2 feet (0.75 m) high can be used).
- (3) Use square knots or half-hitches to make splices or to secure the polytape to corner posts.
- (4) Set 4-foot (1.2-m) 3/8-inch (1-cm) round fiberglass rods along the wires at 45-foot (14-m) intervals.
- (5) Attach the two strands of polytape to insulators on the rods at 1 and 3 feet (0.3 and 0.9 m) above ground level and apply 50 pounds (22.5 kg) of tension.
- (6) Connect the polytape to the positive (+) post of a well-grounded fence charger.
- (7) Use the applicator described under Peanut Butter Fence (8) to apply 2-foot (0.6-m) swatches of peanut butter to the polytape every 6 feet (2 m) where deer presence is expected to be high.

To maintain the fence, check it weekly for damage by deer and grounding by vegetation.

Permanent High-Tensile Electric Fencing

High-tensile fencing can provide year-round protection from deer damage. Many designs are available to meet specific needs. All require strict adherence to construction guidelines concerning rigid corner assemblies and fence configurations. Frequent inspection and maintenance are required. High-tensile fences are expected to last 20 to 30 years. Different types of high-tensile electric fences are described below.

Offset or Double Fence. This fence is mostly for gardens, truck farms, or nurseries up to about 40 acres (0.16 ha) that experience moderate deer pressure. Deer are repelled by the shock and the three-dimensional nature of the fence. You can add wires if deer pressure increases. Cost, excluding labor, is about \$.35 per linear foot (\$1/m).

To build an offset or double fence (Fig. 8), follow the steps below.

For the outside fence:

- (1) Install swing corner assemblies where necessary (see the section on fence construction—rigid brace assemblies [Fig. 14]).
- (2) String a 12 1/2-gauge (0.26-cm) high-tensile wire around the

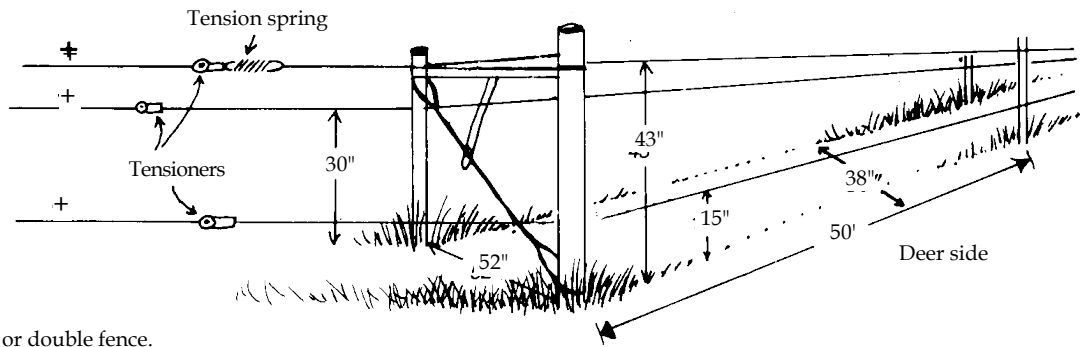

Fig. 8. The offset or double fence.

outside of the swing corner assemblies and apply light tension.

- (3) Set 5-foot (1.5-m) line posts along the wire at 40- to 60-foot (12- to 18-m) intervals.
- (4) Attach the wire to insulators on the line posts, 15 inches (38 cm) above ground level and apply 150 to 250 pounds (68 to 113 kg) of tension.
- (5) String a second wire at 43 inches (109 cm) and apply 150 to 250 pounds (68 to 113 kg) of tension.

For the inside fence:

- (6) String a wire around the inside of the swing corner assemblies and apply light tension.
- (7) Set 5-foot (1.5-m) line posts along the wire at 40- to 60-foot (12- to 18-m) intervals.

- (8) Attach the wire to insulators on the line posts at 30 inches (76 cm) above ground level.
- (9) Attach all wires to the positive (+) post of a well-grounded, low-impedance fence charger.
- (10) Clear and maintain a 6- to 12-foot (1.8- to 3.6-m) open area outside the fence so deer can see it.

Maintenance includes weekly fence and voltage checks.

Vertical Deer Fence. Vertical fences are effective at protecting large truck gardens, orchards, and other fields from moderate to high deer pressures. Because of the prescribed wire spacing, deer either attempt to go through the fence and are effectively shocked or they are physically impeded by the barrier. Vertical fences use less ground

space than three-dimensional fences, but are probably less effective at inhibiting deer from jumping over fences. There is a wide variety of fence materials, wire spacings, and specific designs you can use. We recommend that you employ a local fence contractor. Costs, excluding labor, range from \$0.75 to \$1.50 per linear foot (\$2 to \$4/m).

To build a 7-wire vertical deer fence (Fig. 9), follow the steps below.

- (1) Install rigid corner assemblies where necessary (see the section on fence construction—rigid brace assemblies [Fig. 14]).
- (2) String a 12 1/2-gauge (0.26-cm) high-tensile wire around the corner assemblies and apply light tension.
- (3) Set 8-foot (2.4-m) line posts along

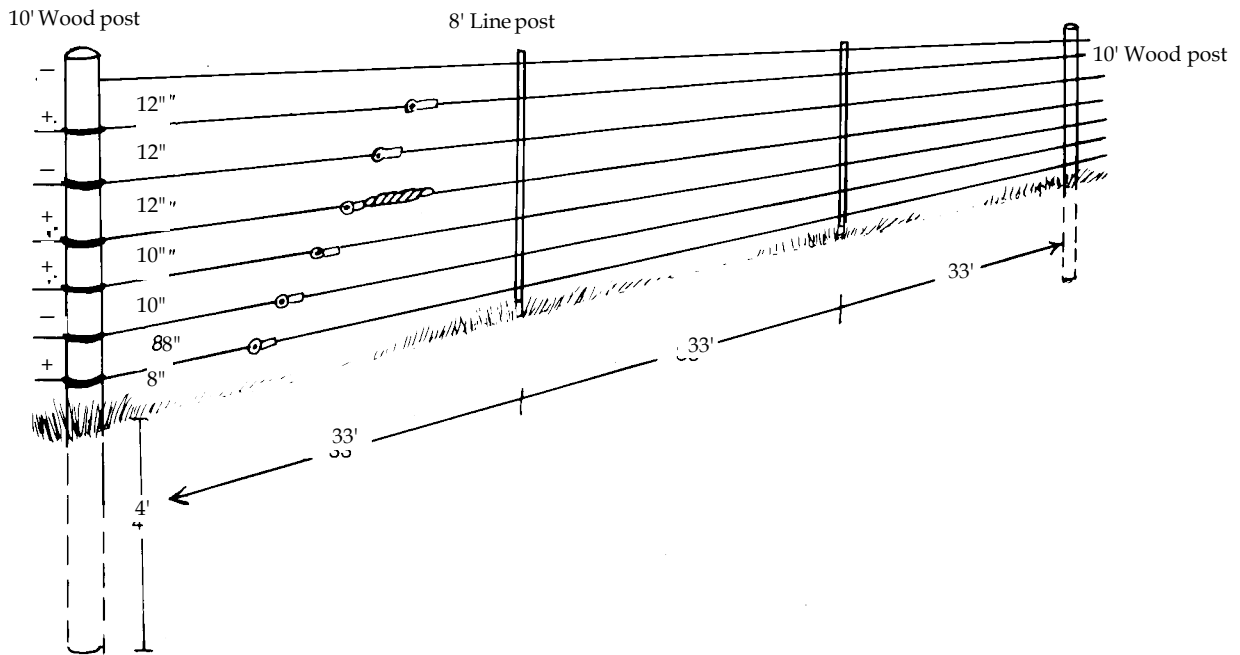

Fig. 9. The seven-wire vertical deer fence.

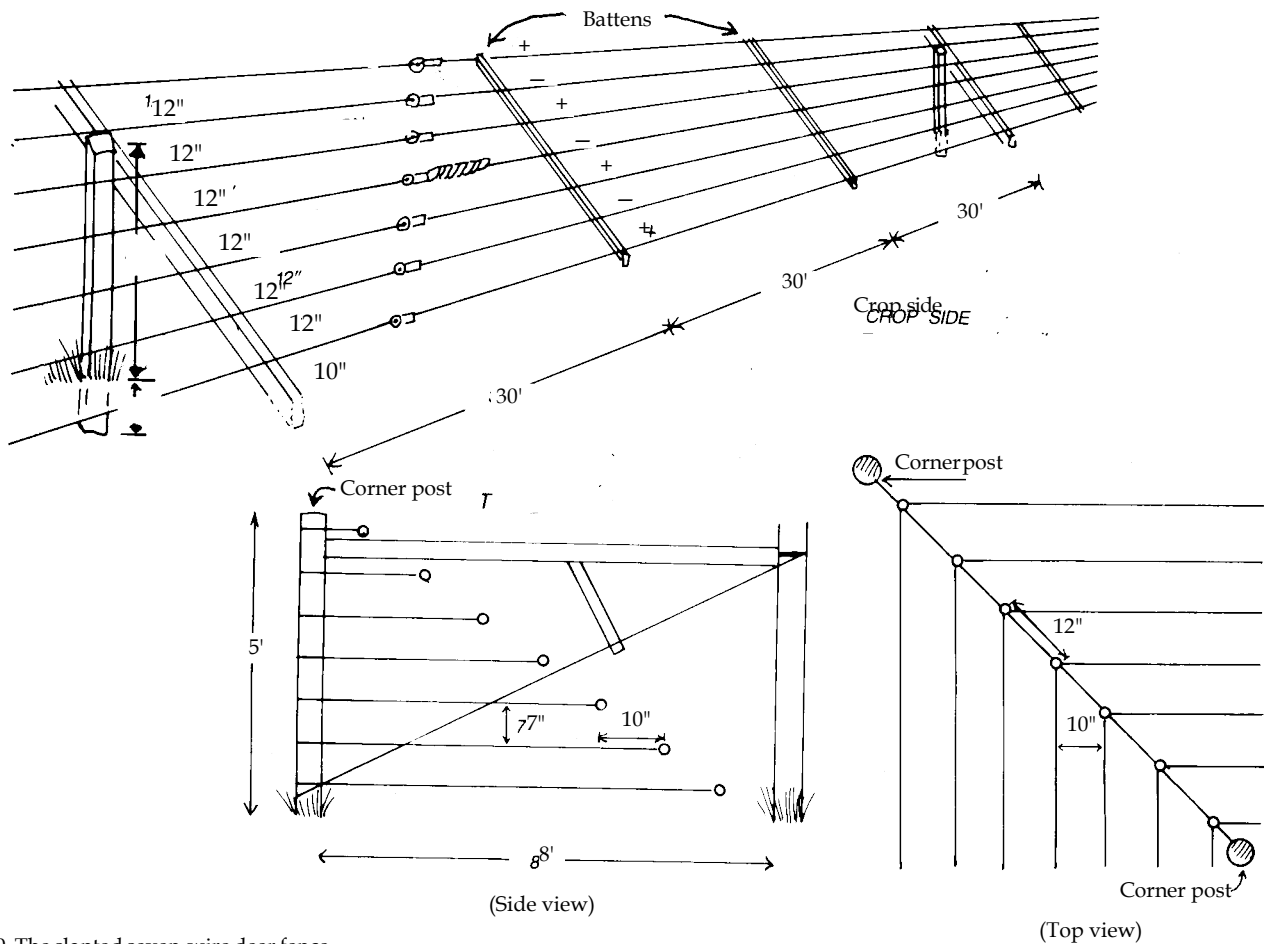

Fig. 10. The slanted seven-wire deer fence.

the wire at 33-foot (10-m) intervals.

- (4) Attach a wire to insulators at 8 inches (20 cm) above ground level and apply 150 to 250 pounds (68 to 113 kg) of tension.
- (5) Attach the remaining wires to insulators at the spacing indicated in figure 9 and apply 150 to 250 pounds (68 to 113 kg) of tension.
- (6) Connect the second, fourth, fifth, and seventh wires from the top, to the positive (+) post of a well-grounded, low-impedance fence charger.
- (7) Connect the top, third, and sixth wires directly to ground. The top wire should be negative for lightning protection.
- (8) Clear and maintain a 6- to 12-foot (1.8- to 3.6-m) open area outside the fence so deer can see the fence.

Maintenance includes weekly fence inspection and voltage checks.

Slanted Seven-Wire Deer Fence.

This fence is used where high deer pressures threaten moderate-to-large sized orchards, nurseries and other high-value crops. It presents a physical and psychological barrier to deer because of its electric shock and three-dimensional nature. Cost, excluding labor, is about \$0.75 to \$2 per linear foot (\$2 to \$5.50/m).

To build a slanted seven-wire deer fence (Fig. 10), follow the steps below.

- (1) Set rigid, swing corner assemblies where necessary, (see the section on fence construction—rigid brace assemblies [Fig. 14]).
- (2) String 12 1/2-gauge (0.26-cm) high-tensile wire around the corner assemblies and apply light tension.
- (3) Set angle braces along the wire at 90-foot (27-m) intervals.
- (4) Attach a wire at the 10-inch (25-cm) position and apply 150 pounds (68 kg) of tension.

- (5) Attach the remaining wires at 12-inch (30-cm) intervals and apply 150 pounds (68 kg) of tension.
- (6) Place fence batters at 30-foot (9-m) intervals.
- (7) Connect the top, third, fifth, and bottom wires to the positive (+) post of a well-grounded, low-impedance fence charger.
- (8) Connect the second, fourth, and sixth wires from the top directly to ground.
- (9) Clear and maintain a 6- to 12-foot (1.8- to 3.6-m) area outside the fence so deer can see it.

Maintenance includes weekly inspection and voltage checks.

Permanent Woven-Wire Fencing

Woven-wire fences are used for year-round protection of high-value crops subject to high deer pressures. These fences are expensive and difficult to construct, but easy to maintain. Before

high-tensile electric fencing, woven-wire fences were used most often to protect orchards or nurseries where the high crop value, perennial nature of damage, acreage, and 20-year life span of the fences justified the initial costs. Cost, excluding labor, is about \$2 to \$4 per linear foot (\$5.50 to \$11/m). The high cost has resulted in reduced use of woven-wire fences.

To build a deer-proof woven-wire fence (Fig. 11), follow the steps below.

- (1) Set rigid corner assemblies where necessary (see the section on Fence Construction—Rigid brace assemblies [Fig. 14]).
- (2) String a light wire between two corners and apply light tension.
- (3) Set 16-foot (4.9-m) posts along the wire at 40-foot (12-m) intervals, to a depth of 4 to 6 feet (1.2 to 1.8 m).
- (4) Roll out an 8-foot (2.4-m) roll of high-tensile woven wire along the line posts. Attach one end at ground level to a corner post with steel staples.
- (5) Apply 100 pounds (45 kg) of tension to the wire with a vehicle or fence strainers and attach the wire to line and corner posts with steel staples.
- (6) Repeat steps 4 and 5 as necessary around the perimeter of the fence.

- (7) Attach two strands of high-tensile smooth wire to the top of the fence to raise the height of the entire fence to 9 to 10 feet (2.7 to 3 m).

Minimal maintenance is required. Inspect for locations where deer can crawl under the fence.

Fencing Tips

Materials. Do not buy cheap materials to reduce costs. This will only reduce the effectiveness and life span of the fence. We recommend using:

- (1) Round fiberglass or treated wood posts.
- (2) High-quality galvanized wire and steel components. For high-tensile fences, use 11- to 14-gauge (0.31- to 0.21-cm) wire (minimum tensile strength of 200,000 pounds [90,000 kg] and a minimum breaking strength of 1,800 pounds [810 kg]), tension springs, and in-line tensioners.
- (3) Compression sleeves for splicing wires and making electrical connections.
- (4) Lightning arresters and diverters to protect chargers.
- (5) High-quality fence chargers. Chargers must be approved by Underwriters Laboratories (UL) or the Canadian Standards

Association (CSA). We highly recommend 110-volt chargers. Six- and 12-volt chargers require battery recharging every 2 to 4 weeks. Use solar panels in remote areas to charge batteries continuously. For high-tensile fences, use high-voltage, low-impedance chargers only (3,000 to 5,000 volts and current pulse duration of at most 1/1,000 second).

- (6) Gates. There is no universal gate design because of the many different fence types. Gates should be electrified, well-insulated, and practical for the type of farming operation. Gates range from single strands of electrified wire with gate handles to electrified panel or tubular gates (Fig. 12).

Fence Construction. Fences must be properly constructed—do not deviate from fence construction guidelines.

- (1) Prepare fencelines before construction. It is easier and less expensive to install and maintain fences on clear, level runs. Minimize corners to increase strength and reduce costs.
- (2) Ensure that the electrical system is well grounded at the fence charger and every 1/2 mile (880 m) of fenceline. To ground high-tensile fences, drive four to six ground

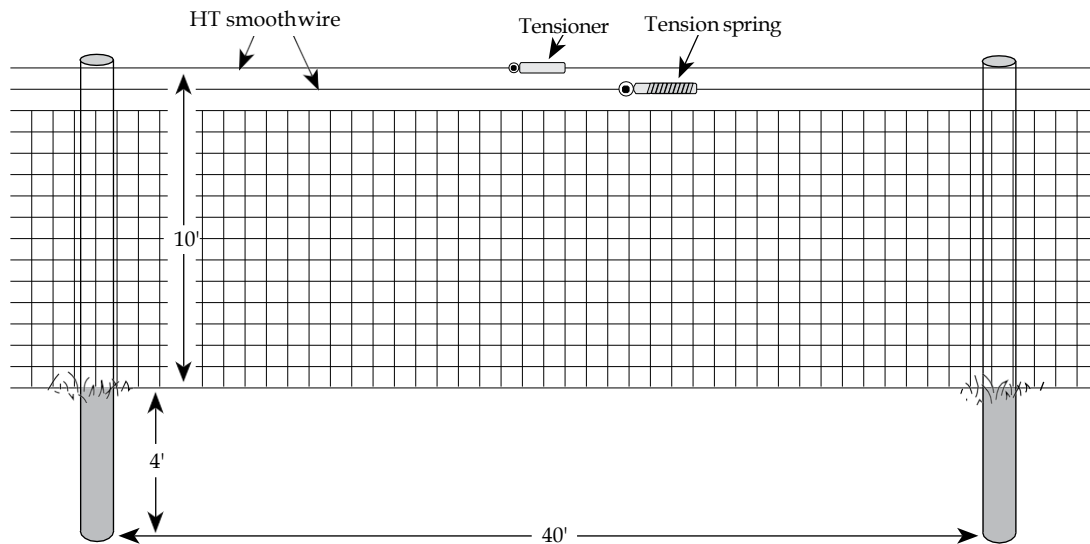

Fig. 11. The deer-proof, woven-wire fence.

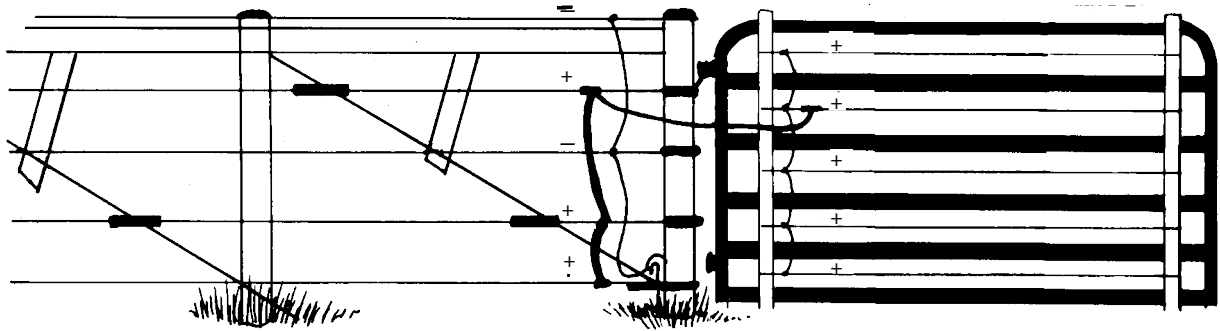

Fig. 12. Fence with electrified gate.

rods 5 to 6 feet (1.5 to 1.8 m) deep and 6 feet (1.8 m) apart. Connect the ground post of the fence charger and the negative (-) wires of the fence to the grounding system (Fig. 13).

- (3) The wiring system in figure 13 illustrates a positive-negative fence. Such a design is especially useful with dry or frozen ground. A fence with all positive (hot) wires may be advantageous under general crop and soil moisture conditions. Consult with a fencing contractor or expert for the best choice for your needs.
- (4) Install the grounding systems and fence charger before fence construction. Energize completed

parts of the fence when you are not working on the fence to gain early protection.

- (5) Rigid brace assemblies—corners, ends, and gates—make up the backbone of all high-tensile fence systems (Fig. 14). They must be entirely rigid, constructed of the best materials, and strictly conform to design guidelines. The single-span brace assembly is the basis of all high-tensile strainer assemblies, regardless of location in the fence or fence design. This basic design is then modified to create double-“H” braces, swing corners, and gate ends.
- (6) Allow wires to slide freely through insulators on fence posts.

Fence flexibility is necessary to endure frequent temperature changes, deer hits, and obstructions.

- (7) Identify an electric fence with warning signs (Fig. 15) that are affixed at 300-foot (90-m) intervals or less.

Maintenance. Regular inspection and maintenance are necessary to ensure the effective operation and longevity of most fences.

- (1) Control vegetation near fences by mowing or applying herbicides to avoid excessive fence grounding by weeds.
- (2) On slopes or highly erodible soils, maintain a good sod cover

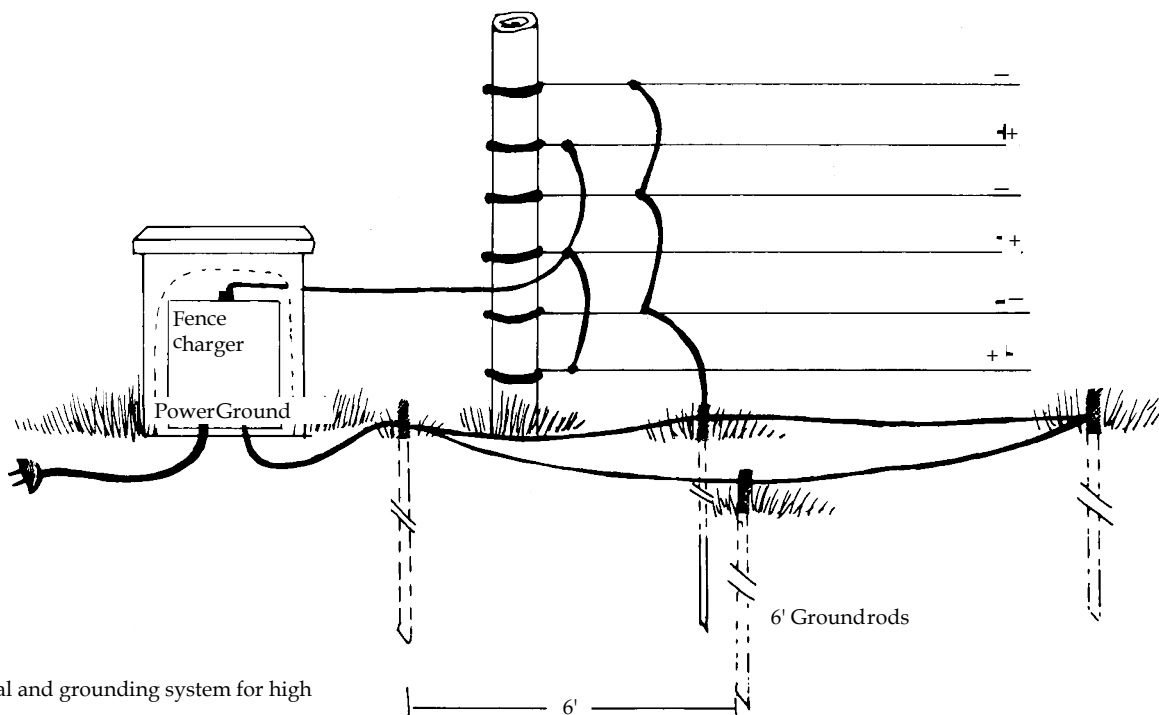

Fig. 13. Electrical and grounding system for high tensile fences.

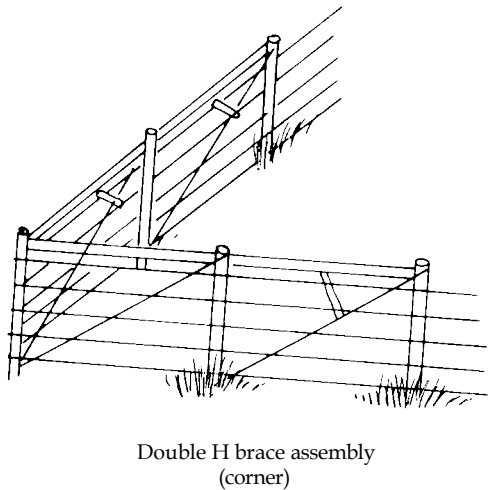
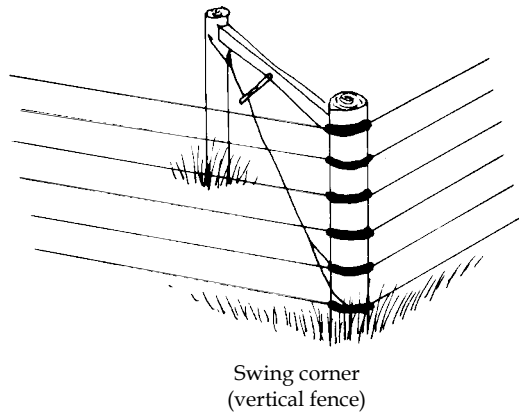
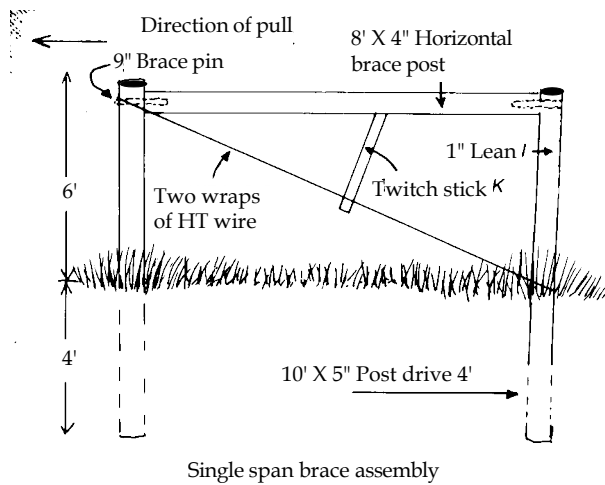

Fig. 14. Rigid brace assemblies.

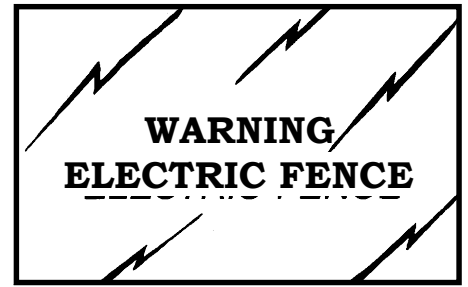

Fig. 15. Remember to attach warning signs to your electric fences.

beneath fences to avoid fenceline erosion.

- (3) Always keep the fence charger on. Check the fence voltage weekly with a voltmeter. Maintain at least 3,000 volts at the furthest distance from the fence charger. Disconnect the lower wires if they are covered by snow.
- (4) In late fall and early summer, adjust the fence tension (150 to 250 pounds [68 to 113 kg]) for high-tensile fences.

Tree Protectors

Use Vexar®, Tubex®, plastic tree wrap, or woven-wire cylinders to protect young trees from deer and rabbits. Four-foot (1.2-m) woven-wire cylinders can keep deer from rubbing tree trunks with their antlers.

Haystack Protection

Wooden panels have traditionally been used to exclude deer and elk from haystacks. Stockyards have also been protected by welded wire panels and woven wire. More recently haystacks have been protected by wrapping them with plastic Tensar® snow fence. The material comes in 8-foot (2.4-m) rolls and is relatively light and easy to use.

Cultural Methods and Habitat Modification

Damage to ornamental plants can be minimized by selecting landscape and garden plants that are less preferred by deer. In many cases, original landscape objectives can be met by planting species that have some resistance to

Table 1. Ornamental plants, listed by susceptibility to deer damage.¹**Plants Rarely Damaged:**

<i>Botanical name</i>	<i>Common name</i>
<i>Berberis</i> spp.	Barberry
<i>Berberis vulgaris</i>	Common Barberry
<i>Betula papyrifera</i>	Paper Birch
<i>Buxus sempervirens</i>	Common Boxwood
<i>Elaeagnus angustifolia</i>	Russian Olive
<i>Ilex opaca</i>	American Holly
<i>Leucothoe fontanesiana</i>	Drooping Leucothoe
<i>Picea pungens</i>	Colorado Blue Spruce
<i>Pieris japonica</i>	Japanese Pieris

Plants Seldom Severely Damaged:

<i>Botanical name</i>	<i>Common name</i>
<i>Betula pendula</i>	European White Birch
<i>Calistrus scandens</i>	American Bittersweet
<i>Cornus sericea</i>	Red Osier Dogwood
<i>Cornus florida</i>	Flowering Dogwood
<i>Cornus kousa</i>	Kousa Dogwood
<i>Crataegus laevigata</i>	English Hawthorn
<i>Enkianthus campanulatus</i>	Redvein Enkianthus
<i>Fagus sylvatica</i>	European Beech
<i>Forsythia</i> spp.	Forsythia
<i>Gleditsia triacanthos</i>	Honey Locust
<i>Ilex cornuta</i>	Chinese Holly
<i>Ilex glabra</i>	Inkberry
<i>Juniperus chinensis</i>	Chinese Junipers (green)
<i>Juniperus chinensis</i>	Chinese Junipers (blue)
<i>Kalmia latifolia</i>	Mountain Laurel
<i>Kolkwitzia amabilis</i>	Beautybush
<i>Picea abies</i>	Norway Spruce
<i>Picea glauca</i>	White Spruce
<i>Pinus nigra</i>	Austrian Pine
<i>Pinus rigida</i>	Pitch Pine
<i>Pinus mugo</i>	Mugo Pine
<i>Pinus resinosa</i>	Red Pine
<i>Pinus sylvestris</i>	Scots Pine
<i>Prunus serrulata</i>	Japanese Flowering Cherry
<i>Salix matsudana tortuosa</i>	Corkscrew Willow
<i>Sassafras albidum</i>	Common Sassafras
<i>Syringa vulgaris</i>	Common Lilac
<i>Wisteria floribunda</i>	Japanese Wisteria

Plants Occasionally Severely Damaged:

<i>Botanical name</i>	<i>Common name</i>
<i>Abies concolor</i>	White Fir
<i>Acer griseum</i>	Paperbark Maple
<i>Acer rubrum</i>	Red Maple
<i>Acer saccharinum</i>	Silver Maple
<i>Acer saccharum</i>	Sugar Maple
<i>Aesculus hippocastanum</i>	Common Horsechestnut
<i>Amelanchier arborea</i>	Downy Serviceberry
<i>Amelanchier laevis</i>	Allegheny Serviceberry
<i>Campsis radicans</i>	Trumpet Creeper
<i>Chaenomeles speciosa</i>	Japanese Flowering Quince
<i>Cornus racemosa</i>	Panicked Dogwood
<i>Cotinus coggygria</i>	Smokebush
<i>Cotoneaster</i> spp.	Cotoneaster
<i>Cotoneaster apiculatus</i>	Cranberry Cotoneaster
<i>Cotoneaster horizontalis</i>	Rockspray Cotoneaster
<i>Cryptomeria japonica</i>	Japanese Cedar
<i>Forsythia (x) intermedia</i>	Border Forsythia
<i>Hamamelis virginiana</i>	Common Witchhazel
<i>Hibiscus syriacus</i>	Rose of Sharon
<i>Hydrangea arborescens</i>	Smooth Hydrangea
<i>Hydrangea anomala petiolaris</i>	Climbing Hydrangea
<i>Hydrangea paniculata</i>	Panicle Hydrangea

Plants Occasionally Severely Damaged (cont.):

<i>Botanical name</i>	<i>Common name</i>
<i>Ilex crenata</i>	Japanese Holly
<i>Ilex (x) meserveae</i>	China Girl/Boy Holly
<i>Juniperus virginiana</i>	Eastern Red Cedar
<i>Larix decidua</i>	European Larch
<i>Lonicera (x) heckrottii</i>	Goldflame Honeysuckle
<i>Ligustrum</i> spp.	Privet
<i>Magnolia (x) soulangiana</i>	Saucer Magnolia
<i>Metasequoia glyptostroboides</i>	Dawn Redwood
<i>Parthenocissus quinquefolia</i>	Virginia Creeper
<i>Philadelphus coronarius</i>	Sweet Mock Orange
<i>Pinus strobus</i>	Eastern White Pine
<i>Potentilla fruticosa</i>	Bush Cinquefoil
<i>Prunus avium</i>	Sweet Cherry
<i>Pseudotsuga menziesii</i>	Douglas Fir
<i>Pyracantha coccinea</i>	Firethorn
<i>Pyrus calleryana 'Bradford'</i>	Bradford Callery Pear
<i>Pyrus communis</i>	Common Pear
<i>Quercus alba</i>	White Oak
<i>Quercus prinus</i>	Chestnut Oak
<i>Quercus rubra</i>	Northern Red Oak
<i>Rhododendron</i> spp.	Deciduous Azaleas
<i>Rhododendron carolinianum</i>	Carolina Rhododendron
<i>Rhododendron maximum</i>	Rosebay Rhododendron
<i>Rhus typhina</i>	Staghorn Sumac
<i>Rosa multiflora</i>	Multiflora Rose
<i>Rosa rugosa</i>	Rugosa Rose
<i>Salix</i> spp.	Willows
<i>Spiraea (x) bumalda</i>	Anthony Waterer Spiraea
<i>Spiraea prunifolia</i>	Bridalwreath Spiraea
<i>Syringa (x) persica</i>	Persian Lilac
<i>Syringa reticulata</i>	Japanese Tree Lilac
<i>Syringa villosa</i>	Late Lilac
<i>Tilia cordata 'Greenspire'</i>	Greenspire Littleleaf Linden
<i>Tilia americana</i>	Basswood
<i>Tsuga canadensis</i>	Eastern Hemlock
<i>Tsuga caroliniana</i>	Carolina Hemlock
<i>Viburnum (x) juddii</i>	Judd Viburnum
<i>Viburnum rhytidophyllum</i>	Leatherleaf Viburnum
<i>Viburnum plicatum tomentosum</i>	Doublefile Viburnum
<i>Viburnum carlesii</i>	Koreanspice Viburnum
<i>Weigela florida</i>	Oldfashion Weigela

Plants Frequently Severely Damaged:

<i>Botanical name</i>	<i>Common name</i>
<i>Abies balsamea</i>	Balsam Fir
<i>Abies fraseri</i>	Fraser Fir
<i>Acer platanoides</i>	Norway Maple
<i>Cercis canadensis</i>	Eastern Redbud
<i>Chamaecyparis thyoides</i>	Atlantic White Cedar
<i>Clematis</i> spp.	Clematis
<i>Cornus mas</i>	Cornelian Dogwood
<i>Euonymus alatus</i>	Winged Euonymus
<i>Euonymus fortunei</i>	Wintercreeper
<i>Hedera helix</i>	English Ivy
<i>Malus</i> spp.	Apples
<i>Prunus</i> spp.	Cherries
<i>Prunus</i> spp.	Plums
<i>Rhododendron</i> spp.	Rhododendrons
<i>Rhododendron</i> spp.	Evergreen Azaleas
<i>Rhododendron catawbiense</i>	Catawba Rhododendron
<i>Rhododendron periclymenoides</i>	Pinxterbloom Azalea
<i>Rosa (x) hybrid</i>	Hybrid Tea Rose
<i>Sorbus aucuparia</i>	European Mountain Ash
<i>Taxus</i> spp.	Yews
<i>Taxus baccata</i>	English Yew
<i>Taxus brevifolia</i>	Western Yew
<i>Taxus cuspidata</i>	Japanese Yew
<i>Taxus (x) media</i>	English/Japanese Hybrid Yew
<i>Thuja occidentalis</i>	American Arborvitae

¹from M. J. Fargione, P. D. Curtis, and M. E. Richmond. 1991. Resistance of woody ornamental plants to deer damage. Cornell Coop. Ext. Fact Sheet. Ithaca, NY. 4pp.

deer damage. Table 1 provides a list of plants, ranked by susceptibility to deer damage. This list, developed by researchers at Cornell University, is applicable for most eastern and northern states. A similar list with a western emphasis was produced by Cummings et al. (1980).

Harvest crops as early as possible to reduce the period of vulnerability to deer. Plant susceptible crops as far from wooded cover as possible to reduce the potential for severe damage. Habitat modification is not recommended. Destruction of wooded or brushy cover in hopes of reducing deer use would destroy valuable habitat for other wildlife. Also, since deer forage over a large area it is unlikely that all available deer cover would be on a farmer's or rancher's land.

Lure crops have been planted to attract deer away from highways and crop fields where deer traditionally caused damage. Their effectiveness has been variable and concern has been raised that an artificial food source may eventually increase deer densities and resultant problems. Specific recommendations are not yet available regarding plant selection, timing, and proximity of lure crops.

Contraception

Promising research on the use of chemosterilants and immunocontraception to reduce or eliminate reproduction is underway. Specificity, efficacy, and delivery of contraceptive agents, however, continue to be problems. The use of contraception for herd control will be best suited to urban parks, refuges, and other discrete areas. It is unlikely that contraception can or will be applied in rural/agricultural landscapes.

Frightening

One of the keys to success with frightening devices and repellents is to take action at the first sign of a problem. It is difficult to break the movements or behavioral patterns of deer once they have been established. Also, use frightening devices and repellents at those times when crops are most susceptible

to damage, for example, the silking to tasseling stages for field corn or the blossom stage for soybeans.

Gas exploders set to detonate at regular intervals are the most commonly used frightening devices for deer. They can be purchased for \$200 to \$500 from several commercial sources (see **Supplies and Materials**). The devices are sometimes available on loan from wildlife refuges or agencies as they are frequently used to control waterfowl damage. To maximize the effectiveness of exploders, move them every few days and stagger the firing sequence. Otherwise, the deer quickly become accustomed to the regular pattern. The noise level can be increased by raising exploders off the ground. Motion-activated firing mechanisms are now being explored to increase the effectiveness of exploders. Success depends on many factors and can range from good to poor. A dog on a long run or restricted by an electronic invisible fence system can keep deer out of a limited area, but care and feeding of the dog can be time-consuming. Free-running dogs are not advisable and may be illegal.

Shell crackers, fireworks, and gunfire can provide quick but temporary relief from deer damage. Equip mobile units with pyrotechnics, spotlights, and two-way radios. Patrol farm perimeters and field roads at dusk and throughout the night during times of the year when crops are most susceptible to damage. Such tactics cannot be relied on for an entire growing season.

Repellents

Repellents are best suited for use in orchards, gardens, and on ornamental plants. High cost, limitations on use, and variable effectiveness make most repellents impractical on row crops, pastures, or other large areas. Success with repellents is measured in the reduction, not total elimination, of damage.

Repellents are described by mode of actions as "contact" or "area." Contact repellents, which are applied directly to the plants, repel by taste. They are most effective when applied to trees

and shrubs during the dormant period. New growth that appears after treatment is unprotected. Contact repellents may reduce the palatability of forage crops and should not be used on plant parts destined for human consumption. Hinder® is an exception in that it can be applied directly on edible crops.

Area repellents are applied near the plants to be protected and repel deer by odor alone. They are usually less effective than contact repellents but can be used in perimeter applications and some situations where contact repellents cannot.

During the winter or dormant season, apply contact repellents on a dry day when temperatures are above freezing. Treat young trees completely. It will be more economical to treat only the terminal growth of older trees. Be sure to treat to a height of 6 feet (1.8 m) above expected maximum snow depth. During the growing season, apply contact repellents at about half the concentration recommended for winter use.

The effectiveness of repellents will depend on several factors. Rainfall will dissipate some repellents, so reapplication may be necessary after a rain. Some repellents do not weather well even in the absence of rainfall. Deer's hunger and the availability of other more palatable food will have a great effect on success. In times of food stress, deer are likely to ignore either taste or odor repellents. When using a commercial preparation, follow the manufacturer's instructions. Don't overlook new preparations or imaginative ways to use old ones. The following discussion of common repellents is incomplete and provided only as a survey of the wide range of repellent formulations available. The repellents are grouped by active ingredient. Trade names and sample labels for some products are provided in the **Supplies and Materials** section.

Deer-Away® Big Game Repellent (37% putrescent whole egg solids). This contact (odor/taste) repellent has been used extensively in western conifer plantations and reported in field

studied to be 85% to 100% effective. It is registered for use on fruit trees prior to flowering, as well as ornamental and Christmas trees. Apply it to all susceptible new growth and leaders. Applications weather well and are effective for 2 to 6 months. One gallon (3.8 l) of liquid or 1 pound (0.45 kg) of powder costs about \$32 and covers 400, 3-inch (7.6-cm) saplings or 75, 4-foot (1.2-m) evergreens.

Hinder® (15% ammonium soaps of higher fatty acids). This area repellent is one of the few registered for use on edible crops. You can apply it directly to vegetable and field crops, forages, ornamentals, and fruit trees. Its effectiveness is usually limited to 2 to 4 weeks but varies because of weather and application technique. Reapplication may be necessary after heavy rains. For small fields and orchards, you can treat the entire area. For larger areas, apply an 8- to 15-foot (2.4- to 4.6-m) band around the perimeter of the field. Apply at temperatures above 32°F (0°C). Four gallons (15.2 l) of liquid cost about \$80, and when mixed with 100 gallons (380 l) of water will cover 1 acre (0.4 ha). Hinder is compatible for use with most pesticides.

Thiram (7% to 42% tetramethylthiuram disulfide). Thiram, a fungicide that acts as a contact (taste) deer repellent, is sold under several trade names—Bonide Rabbit-Deer Repellent®, Nott's Chew-Not, and Gustafson 42-S®, among others. It is most often used on dormant trees and shrubs. A liquid formulation is sprayed or painted on individual trees. Although Thiram itself does not weather well, adhesives such as Vapor Gard® can be added to increase its resistance to weathering. Thiram-based repellents also protect trees against rabbit and mouse damage. Two gallons (7.6 l) of 42% Thiram cost about \$50 and when mixed with 100 gallons (380 l) of water will cover 1 acre (0.4 ha). Cost varies with the concentration of Thiram in the product.

Miller's Hot Sauce® Animal Repellent (2.5% capsaicin). This contact (taste) repellent is registered for use on ornamentals, Christmas trees,

and fruit trees. Apply the repellent with a backpack or trigger sprayer to all susceptible new growth, such as leaders and young leaves. Do not apply to fruit-bearing plants after fruit set. Vegetable crops also can be protected if sprayed prior to the development of edible parts. Weatherability can be improved by adding an anti-transpirant such as Wilt-Pruf® or Vapor Gard®. Hot Sauce and Vapor Gard® cost about \$80 and \$30 per gallon (3.8 l) respectively. Eight ounces (240 ml) of Hot Sauce and two quarts (1.9 l) of anti-transpirant mixed with 100 gallons (380 l) of water will cover 1 acre (0.4 ha).

Tankage (putrefied meat scraps). Tankage is a slaughterhouse by-product traditionally used as a deer repellent in orchards. It repels deer by smell, as will be readily apparent. To prepare containers for tankage, remove the tops from aluminum beverage cans, puncture the sides in the middle of the cans to allow for drainage and attach the cans to the ends of 4-foot (1.2 m) stakes. Drive the stakes into the ground, 1 foot (0.3 m) from every tree you want to protect or at 6-foot (1.8-m) intervals around the perimeter of a block. Place 1 cup (225 g) of tankage in each can. You can use mesh or cloth bags instead of cans. You may have to replace the containers periodically because fox or other animals pull them down occasionally. Tankage is available by bulk (\$335 per ton [\$302/mt]) or bag (\$20 per 50 pounds [22.5 kg]). When prepared for hanging on stakes, it costs about \$0.20 per 1 ounce (28 g) bag and 300 bags will cover 2 acres (0.8 ha).

Ro-pel® (benzyl-diethyl [(2,6 xylyl-carbamoyl) methyl] ammonium saccharide (0.065%), thymol (0.035%)). Ro-pel® is reported to repel deer with its extremely bitter taste. Apply Ro-pel® once each year to new growth. It is not recommended for use on edible crops. Spray at full strength on nursery and Christmas trees, ornamentals, and flowers. One gallon (3.8 l) costs \$50 and covers about 1 acre (0.4 ha) of 8- to 10-foot (2.4- to 3.0-m) trees.

Hair Bags (human hair). Human hair is an odor (area) repellent that costs very little but has not consistently repelled deer. Place two handfuls of hair in fine-mesh bags (onion bags, nylon stockings). Where severe damage occurs, hang hair bags on the outer branches of individual trees with no more than 3 feet (0.9 m) between individual bags. For larger areas, hang several bags, 3 feet (0.9 m) apart, from a fence or cord around the perimeter of the area to be protected. Attach the bags early in spring and replace them monthly through the growing season. You can get hair at local barber shops or salons.

Bar Soap. Recent studies and numerous testimonials have shown that ordinary bars of soap applied in the same manner as hair bags can reduce deer damage. Drill a hole in each bar and suspend it with a twist tie or soft cord. Each bar appears to protect a radius of about 1 yard (1 m). Any inexpensive brand of bar soap will work. Ready-to-use bars cost about \$0.20 each.

Toxicants

No toxicants are registered for deer control. Poisoning of deer with any product for any reason is illegal and unlikely to be tolerated by the public.

Herd Reduction

Overall reduction in a state's deer population might reduce deer damage, but public opinion generally does not favor this approach. Damage may result from a few problem deer or at locations close to a winter deer yard or other exceptional habitat. Thus, a local reduction in deer population may be appropriate.

Live Capture

In special cases, such as city parks, refuges, or suburban neighborhoods, it may be necessary or desirable to capture deer alive and move them to other areas. Deer can be captured safely with rocket nets, drop-door box traps, or tranquilizer guns, but these techniques are expensive, time-consuming, and require the expertise

of professional wildlife biologists. Live capture and relocation is seldom a practical alternative unless delicate public relations problems mandate live removal as the only choice. During 1982, 15 deer were removed from a Milwaukee, Wisconsin nature area using chemical immobilization. Total cost was about \$100 per deer but other more recent removal operations have been more expensive, up to \$400 per deer or more. In addition to high costs, the survival of relocated deer is usually low. Live removal is seldom justified.

Shooting

Effective use of the legal deer season is probably the best way to control deer populations. By permitting hunting, landowners provide public access to a public resource while at the same time reducing deer damage problems. Because of the daily and seasonal movements of deer, only rarely does a single landowner control all the land a deer uses. As a result, neighboring landowners should cooperate. Landowners, the state wildlife agency, and local hunters should reach a consensus about a desirable population level for an area before deer are removed.

Mechanisms for managing deer population levels in a specific area already exist in most states. Either-sex seasons, increased bag limits, antlerless-only permits, special depredation seasons, and a variety of other management techniques have been used successfully to reduce deer numbers below levels achieved by traditional "bucks only" regulations.

Shooting permits issued by some states allow for removal of problem deer where they are causing damage during nonhunting season periods.

Use of bait, spotlights, and rifles may increase success but techniques must be consistent with the specifications of the permits. In areas where shooting normally is prohibited, such as parks and densely populated areas, a skilled shooter under permit is probably preferable to costly attempts at live removal.

Economics of Damage and Control

A national survey conducted by USDA's National Agricultural Statistics Service in 1992 identified deer damage as the most widespread form of wildlife damage. Forty percent of the farmers reporting had experienced deer damage. No estimate exists of nationwide annual crop losses to deer, but damage estimates have been made for some states. In Wisconsin, a 1984 survey of farmers suggested minimum statewide deer damage of \$36.7 million annually. A similar study in Pennsylvania estimated the annual crop loss at \$16 to \$30 million. The situation is similar in most agricultural states with moderate to high deer densities. Estimates by Hesselton and Hesselton (1982) suggest that the cost of deer-vehicle collisions may exceed \$100 million each year in the United States and Canada. In fact, the cost of deer/vehicle collisions was estimated at \$100 million in Wisconsin alone in 1990.

Deer also damage nurseries, landscape plantings, and timber regeneration. However, as established earlier, deer are a valuable public resource. Cost estimates for control techniques were presented with the appropriate techniques. A cost/benefit analysis is always advisable before initiating a control program.

Two additional economic aspects are worth consideration. One involves farmer tolerance for deer damage. Two summaries of social science research related to deer damage (Pomerantz et al. 1986, and Siemer and Decker 1991) demonstrated that a majority of farmers were willing to tolerate several hundred dollars in deer damage in exchange for the various benefits of having deer on their land. Thus "total damage" figures are misleading because only a small percentage of the farmers statewide or nationwide are suffering sufficient damage to warrant control or compensation.

The second economic consideration involves state-funded programs of subsidies for damage control materials or direct compensation for crop losses. Such programs can be very costly but are probably necessary where large deer herds are maintained in agricultural landscapes. As an example, the Wisconsin Wildlife Damage Program expended \$2.25 million in 1992 for abatement materials, claims, and administration. The program is a collaborative effort of the Wisconsin Department of Natural Resources, USDA-APHIS-ADC, and Wisconsin counties and is very effective. Individual states vary greatly, however, in their degree of financial or technical assistance. Consult your state wildlife agency for information on compensation or cost-sharing programs. Also, many states have local publications on deer and deer damage--Pennsylvania, Wisconsin, Minnesota, Michigan, and New York, for example. Consult your local Extension office or state wildlife agency.

Acknowledgments

Figures 1 and 5 from Schwartz and Schwartz (1981).

Figure 2 by Charles W. Schwartz, published in Wallmo (1978), copyrighted by the Wildlife Management Institute and adapted by Emily Oseas Routman.

Figures 3 and 4 adapted from Burt and Grossenheider (1976) by Jill Sack Johnson.

Figures 6 through 15 are from Craven and Hygnstrom (1993), "Controlling Deer Damage in Wisconsin," University of Wisconsin Extension publication G3083.

For Additional Information

Andelt, W. F., K. P. Burnham, and J. A. Manning. 1991. Relative effectiveness of repellents for reducing mule deer damage. *J. Wildl. Manage.* 55:341-347.

Burt, W. H., and R. P. Grossenheider. 1976. *A field guide to the mammals*, 3d ed. Houghton Mifflin Co., Boston. 289 pp.

Conover, M. R. 1984. Effectiveness of repellents in reducing deer damage in nurseries. *Wildl. Soc. Bull.* 12:399-404.

Cummings, M. W., M. H. Kimball, and W. M. Longhurst. 1980. Deer-resistant plants for ornamental use. Leaflet 2167. Div. Agric. Sci., Univ. California. Oakland. 7 pp.

Fargione, M. J., P. D. Curtis, and M. E. Richmond. 1991. Resistance of woody ornamental plants to deer damage. Cornell Coop. Ext. Fact Sheet. Ithaca, NY. 4 pp.

Gallagher, B. 1992. 9th international power fence manual. Gallagher Power Fence, Inc., San Antonio, Texas. 45 pp.

Halls, L. K. 1978. White-tailed deer. Pages 43-65 in J. L. Schmidt and D. L. Gilbert, eds. *Big game of North America: ecology and management*. Stackpole Books, Harrisburg, Pennsylvania.

Halls, L. K., Ed. 1984. *White-tailed deer: ecology and management*. Stackpole Books, Harrisburg, Pennsylvania. 870 pp.

Harris, M. T., W. L. Palmer, and J. L. George. 1983. Preliminary screening of white-tailed deer repellents. *J. Wildl. Manage.* 47:516-519.

Hesselton, W. T., and R. A. M. Hesselton. 1982. White-tailed deer. Pages 878-901 in J. A. Chapman and G. A. Feldhamer, eds. *Wild mammals of North America: biology, management and economics*. The Johns Hopkins Univ. Press, Baltimore, Maryland.

Mackie, R. J., K. L. Hamlin, and D. F. Pac. 1982. Mule deer. Pages 862-877 in J. A. Chapman and G. A. Feldhamer, eds. *Wild mammals of North America: biology, management and economics*. The Johns Hopkins Univ. Press, Baltimore, Maryland.

Palmer, W. L., R. G. Wingard, and J. L. George. 1983. Evaluation of white-tailed deer repellents. *Wildl. Soc. Bull.* 11:164-166.

Pomerantz, G. A., C. Ng, and D. J. Decker. 1986. Summary of research on human tolerance of wildlife damage. *Nat. Resour. Res. Ext. Ser. No. 25*. Dep. Nat. Resour., Cornell Univ., Ithaca, New York. 42 pp.

Selders, A. W., J. B. McAninch, and R. J. Winchcombe. 1981. High-tensile wire fencing. *Northeast Regional Agric. Eng. Serv. Bull.* 11. Cornell Univ., Ithaca, New York. 14 pp.

Siemer, W. F., and D. J. Decker. 1991. Human tolerance of wildlife damage: synthesis of research and management implications. *Human Dimensions Res. Unit, Ser. No. 91-7*. Dep. Nat. Resour., Cornell Univ., Ithaca, New York. 24 pp.

Stapells, R. D. H. 1983. Everything you should know about electric fences and fence controllers. J. C. Hallman Mfg. Co. Ltd. Kitchaner, Ontario. 30 pp.

Swihart, R. K., and M. R. Conover. 1990. Reducing deer damage to yews and apple trees: testing Big Game Repellent®Ro-pel®, and soap as repellents. *Wildl. Soc. Bull.* 18:156-162.

US Steel Corporation. 1980. How to build fences with USS Max-Ten 200 high-tensile fence wire. No. T-111575 US Steel Corp. Pittsburgh, Pennsylvania. 75 pp.

Wallmo, O. C. 1978. Mule and black-tailed deer. Pages 32-42 in J. L. Schmidt and D. L. Gilbert, eds. *Big game of North America: ecology and management*. Stackpole Books, Harrisburg, Pennsylvania.

Editors

Scott E. Hygnstrom
Robert M. Timm
Gary E. Larson